

# Parker Pelin Star TN Series Needle Valve

Catalog 1011C-A



ENGINEERING YOUR SUCCESS.  
75

# Introduction

Parker PELIN STAR Brand Needle Valves have been designed for use at pressures up to 6,000 (414 bar) and working temperatures up to 1,000 °F (538 °C). A non-rotating lower stem helps to protect packing life by removing rotation from the packing area. Stem packing below the threads isolates lubricant from the media.



# Features

- Safety back seated spindle prevents stem blowout
- Packing below threads to prevent lubricant washout
- Stem swivel above the packing eliminates entrapment area and increases packing life.
- 316 stainless steel construction.
- 100% factory tested.
- NACE compliant wetted parts available

# Specifications

**Pressure Rating:**

6000 psig (414 bar) CWP

**Temperature Rating:**

PTFE Packing:

-65 °F to 500 °F (-54 °C to 260 °C)

**Graphite Packing:**

-65 °F to 1000 °F (-54 °C to 538 °C)

**Orifice:**

6mm



## Pressure vs. Temperature

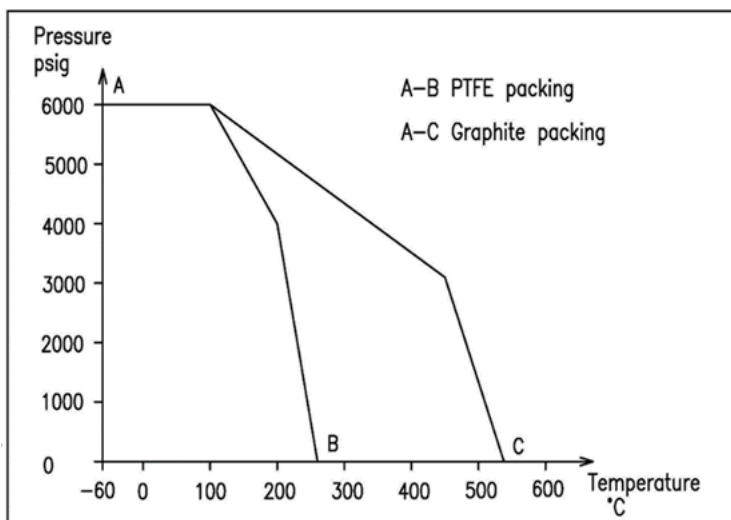

# Construction

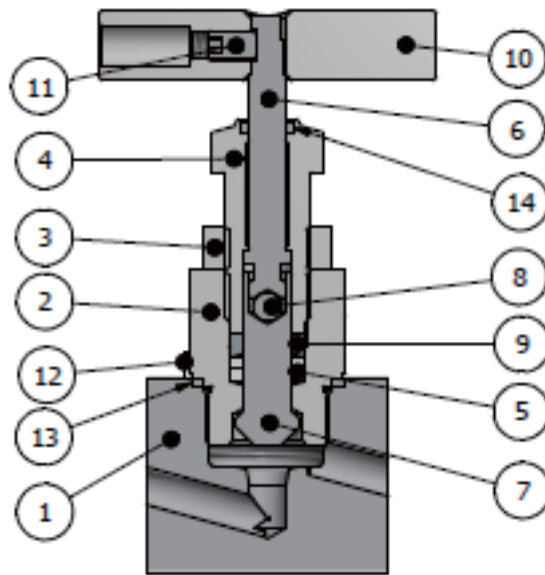

Item	Part	Material
1	Body	ASTM A479 316SS
2	Bonnet	PTFE ASTM D1710
3	Lock Nut	ASTM A479 316SS
4	Packing Nut	ASTM A479 316SS
5	Packing	A2-70 St,St
6	Upper Stem	ASTM A479 316SS
7	Lower Stem	ASTM A479 316SS
8	Ball	ASTM A276 440C
9	Bushing	ASTM A479 316SS
10	Handle	ASTM A479 304SS
11	Set Screw	18-8(1.4310)
12	Lock Pin	A2-70 St,St
13	Gasket	ASTM A479 316SS
14	Dust Seal	Graphite JB/T 7758.2

# How to order

The correct part number is easily derived from the following number sequence. The five product characteristics required are coded as shown below. \*Note: If the inlet and outlet ports are the same eliminate the outlet port designator.

## Example: 8A - TN6L - T - SS

Description a TNV valve with 1/2" A-Lok port connection, 6mm seat, line straight 2 way, PTFE packing, Stainless Steel material body

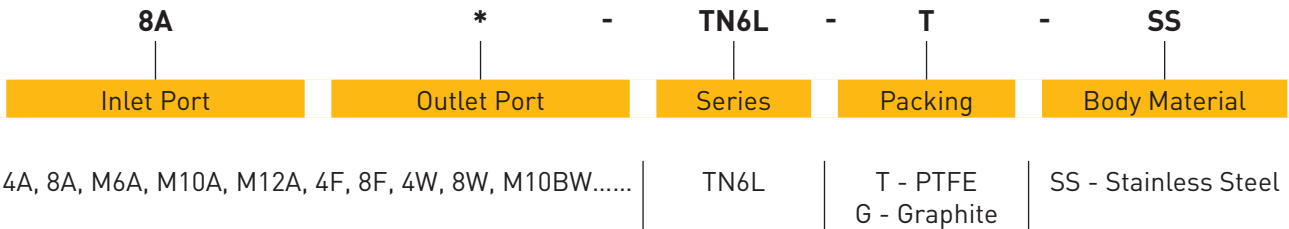

### WARNING

FAILURE, IMPROPER SELECTION OR IMPROPER USE OF THE PRODUCTS AND/OR SYSTEMS DESCRIBED HEREIN OR RELATED ITEMS CAN CAUSE DEATH, PERSONAL INJURY AND PROPERTY DAMAGE.

This document and other information from Parker Hannifin Corporation, its subsidiaries and authorized distributors provide product and/or system options for further investigation by users having technical expertise. It is important that you analyze all aspects of your application and review the information concerning the product or system in the current product catalog. Due to the variety of operating conditions and applications for these products or systems, the user, through its own analysis and testing, is solely responsible for making the final selection of the products and systems and assuring that all performance, safety and warning requirements of the application are met.

The products described herein, including without limitation, product features, specifications, designs, availability and pricing, are subject to change by Parker Hannifin Corporation and its subsidiaries at any time without notice.

### Offer of Sale

The items described in this document are available for sale by Parker Hannifin subsidiaries or its authorized distributors. Any sale contract entered into by Parker will be governed by the provisions stated in Parker's standard terms and conditions of sale (copy available upon request).