



Typical Globe Process Valve

Catalog 1010C-C



ENGINEERING YOUR SUCCESS.

Introduction

Parker Typical Global Process Valve designed and verified under ASME B16.34 and API 598 standard, Port connection per as ASME B16.11, B16.25, ASME class 2500&4500 pressure rate, working temperature up to 1200°F (649°C), provide excellent function performance to high pressure with high temperature pipeline system.



Features

- Integrate structure bonnet, robust safety design
- integral stuffing box frame Graphite packing
- One step removal of bonnet and packing material
- Rotatable disc provides excellent sealing ability
- Stellite disc and seat with long period cycle time
- Socket welding and Butt welding per ANSI B16.11/ANSI B16.25 standard
- Material: ASTM A105, ASTM A182 316H/F91/F92/F22

Remarks: Any other requirement, pls contact Parker

Configuration

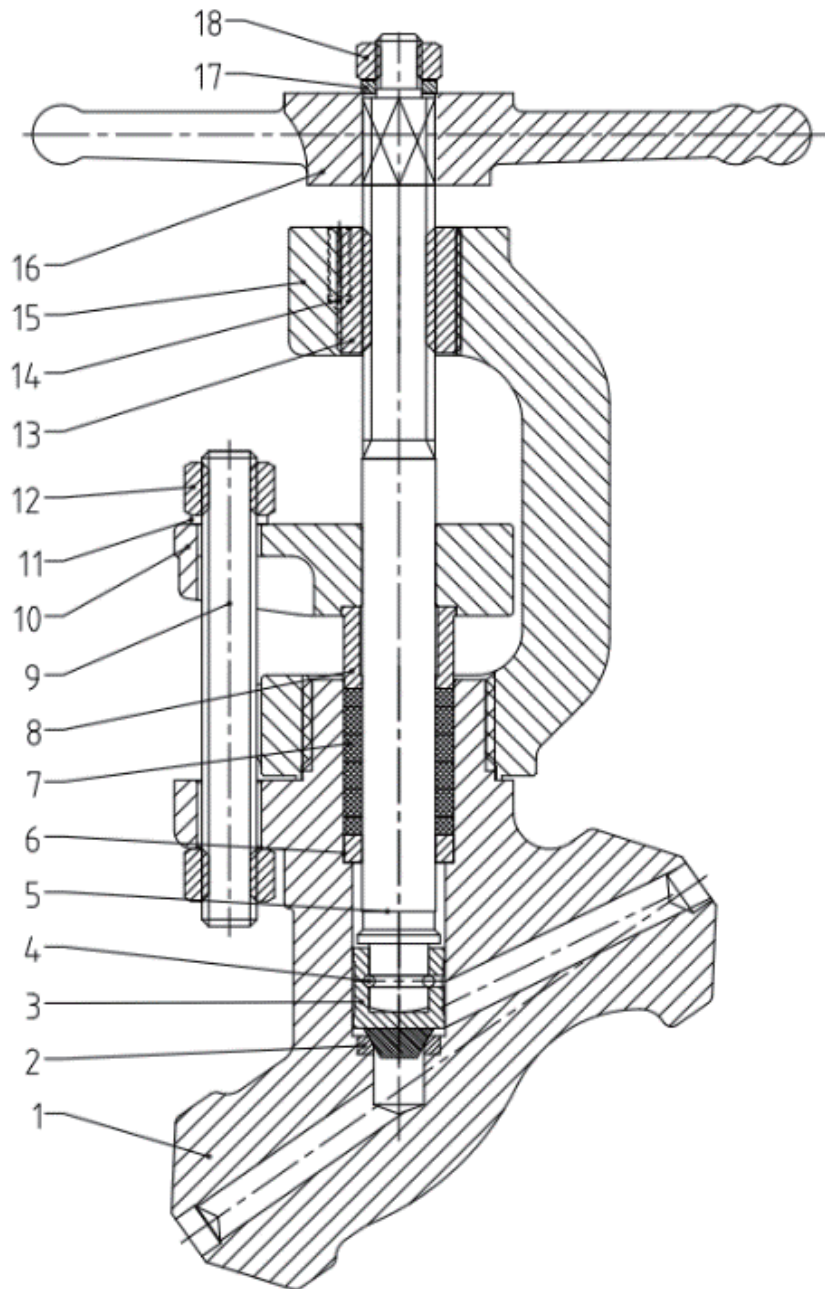

No.	Description
1	Body
2	Seat
3	Disc
4	Ball
5	Stem
6	Packing Seat
7	Packing
8	Packing Gland
9	Packing Adjust

No.	Description
10	Packing Adjuster
11	Washer
12	Nut
13	Bushing
14	Set Screw
15	Bracket
16	Hand Wheel
17	Washer
18	Nut

Working Pressure (Class 4500)

SA 182-F316H

B16.34-2004 Standard Class		B16.34-2004 Limited Class	
Temp (°C)	Working Pressures (bar)	Temp (°C)	Working Pressures (bar)
38	745	38	776
93	641	93	714
149	579	149	646
204	532	204	590
260	494	260	550
316	467	316	521
343	460	343	510
371	450	371	501
399	442	399	492
427	437	427	488
454	432	454	482
482	430	482	479
510	400	510	474
538	362	538	435
566	356	566	435
593	316	593	422
621	245	621	245
649	191	649	191
677	152	677	152

Working Pressure (Class 4500)

F91 forgings

B16.34-2004 Standard Class		B16.34-2004 Limited Class	
Temp (°C)	Working Pressures (bar)	Temp (°C)	Working Pressures (bar)
-29 to 38	776	-29 to 38	776
66	776	66	776
93	776	93	776
121	765	121	776
149	754	149	776
177	742	177	776
204	730	204	776
232	709	232	776
260	688	260	776
288	657	288	776
316	626	316	776
329	617	329	776
343	609	343	776
357	598	357	767
371	588	371	759
385	569	385	756
399	550	399	754
413	538	413	750
427	525	427	745
441	515	441	723
454	504	454	701
468	485	468	661
482	465	482	621
496	432	496	571
510	400	510	521
524	388	524	521
538	376	538	521
552	374	552	521
566	373	566	521
579	342	579	502
593	312	593	483
607	372	607	420
621	231	621	357
635	190	635	294
649	149	649	231

Working Pressure (Class 4500)

F92 forgings

B16.34-2004 Standard Class		B16.34-2004 Limited Class	
Temp (°C)	Working Pressures (bar)	Temp (°C)	Working Pressures (bar)
-29 to 38	776	-29 to 38	776
66	776	66	776
93	776	93	776
121	765	121	776
149	754	149	776
177	742	177	776
204	730	204	776
232	709	232	776
260	688	260	776
288	657	288	776
316	626	316	776
329	617	329	776
343	609	343	776
357	598	357	767
371	588	371	759
385	569	385	756
399	550	399	754
413	538	413	750
427	525	427	745
441	515	441	723
454	504	454	701
468	485	468	661
482	465	482	621
496	432	496	571
510	400	510	521
524	388	524	521
538	376	538	521
552	374	552	521
566	373	566	521
579	353	579	519
593	334	593	517
607	309	607	478
621	284	621	440
**635	190	635	294
**649	149	649	231

** Over 621 °C is limited on outside diameter to below 89MM

Working Pressure (Class 4500)

SA 182-F22

B16.34-2004 Standard Class		B16.34-2004 Limited Class	
Temp (°C)	Working Pressures (bar)	Temp (°C)	Working Pressures (bar)
38	776	38	776
93	776	93	776
149	754	149	767
204	730	204	750
260	688	260	745
316	626	316	745
343	609	343	741
371	588	371	736
399	550	399	714
427	525	427	697
454	504	454	666
482	465	482	621
510	391	510	521
538	270	538	418
566	181	566	280
593	114	593	176

SA 105

B16.34-2004 Standard Class		B16.34-2004 Limited Class	
Temp (°C)	Working Pressures (bar)	Temp (°C)	Working Pressures (bar)
38	767	38	776
93	698	93	776
149	679	149	776
204	656	204	776
260	620	260	776
316	566	316	738
343	556	343	723
371	551	371	718
399	522	399	652
427	426	427	532

Dimension

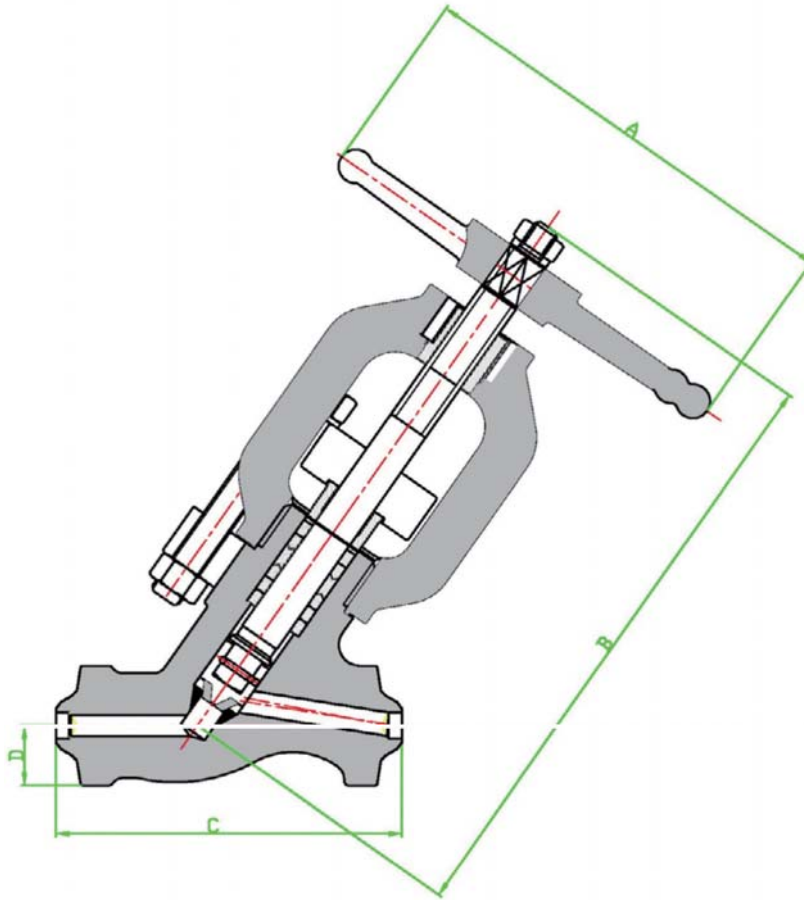

Unit (mm)

Orifice	A	B	C	D	Cv	Weight (Kg)
10 mm	150	236	115	21	1.5	5.4
15 mm	150	236	115	21	1.7	5.3

How to Order

BW	10	-	YT	-	3/8	-	G	-	F91	-	4500	-	A
Port	Size		Typical		Orifice		Packing		Material		Class		Type
BW-Butt Welding SW-Socket Welding	1/2" (10 mm) ~ 1-1/4" (30 mm)		Globe Process Valve		3/8" (DN10) 1/2" (DN15) 3/4" (DN20)		Graphite		F91 F92 F316 F316H F22 A105		4500 CL		A: Modular B: Solid

WARNING

FAILURE, IMPROPER SELECTION OR IMPROPER USE OF THE PRODUCTS AND/OR SYSTEMS DESCRIBED HEREIN OR RELATED ITEMS CAN CAUSE DEATH, PERSONAL INJURY AND PROPERTY DAMAGE.

This document and other information from Parker Hannifin Corporation, its subsidiaries and authorized distributors provide product and/or system options for further investigation by users having technical expertise. It is important that you analyze all aspects of your application and review the information concerning the product or system in the current product catalog. Due to the variety of operating conditions and applications for these products or systems, the user, through its own analysis and testing, is solely responsible for making the final selection of the products and systems and assuring that all performance, safety and warning requirements of the application are met.

The products described herein, including without limitation, product features, specifications, designs, availability and pricing, are subject to change by Parker Hannifin Corporation and its subsidiaries at any time without notice.

Offer of Sale

The items described in this document are available for sale by Parker Hannifin subsidiaries or its authorized distributors. Any sale contract entered into by Parker will be governed by the provisions stated in Parker's standard terms and conditions of sale (copy available upon request).